

**Anchorage Amateur Radio Club, Inc**  
Post Office Box 101987  
Anchorage, Alaska 99510-1987

PRSRT STD  
U.S. Postage  
PAID  
Anchorage, AK  
Permit No. 69

# Ham Radio Classes Now Forming

As a Licensed Ham Radio Operator You Get To:

- Serve Your Community
- Talk To Other Hams On The Radio
- Meet New Friends
- Have Your Own Individual Callsign



The Anchorage Amateur Radio Club will be holding a 4 week course where **YOU** will learn everything you need to earn your entry level FCC **Amateur Radio** license and begin to **talk on the radio with other hams** in the area.



Classes Begin on September 18<sup>th</sup> at 6:30 PM.  
Registration is required (to order materials)  
For more information please contact:  
Kathy O'Keefe, KL7KO,  
907-243-4675  
[kok@woodscross.net](mailto:kok@woodscross.net)



**WHEN:** Monday & Wednesday Evenings (6:30 - 9:00PM)  
September 25 - October 18, 2006 (8 Sessions)

**WHERE:** American Red Cross of Alaska, Anchorage Office  
235 E 8th Avenue, Anchorage, AK

## AMATEUR RADIO CLASS

The Anchorage Amateur Radio Club will be holding a 4 week course meeting two nights per week where students can come and learn everything they need to know to earn an entry level FCC Amateur Radio license and begin to talk on the radio.

The course will take place at the American Red Cross of Alaska headquarters, located at 235 E 8th Avenue, Anchorage Alaska at the corner of 8h and Cordova. The course will be Monday and Wednesday evenings from 630 PM to 9PM for four weeks starting on September 25th through October 18th, 2006. The course will cost \$10 per student to cover the costs of the new ARRL Learning Amateur Radio manual. This manual has the complete updated question pool for obtaining a Technician no-code amateur radio license. A testing session will be available on the last night of the class.

To sign up for this class please contact Kathleen O'Keefe at 907-243-4675 or email: [instructor@kl7aa.net](mailto:instructor@kl7aa.net)

A General and Extra Course is being planned for November and January.

# Anchorage Amateur Radio Club

Next Meeting September 1st

## September Program

Ed Moses, KL1KL



Aves Thompson and Jess Seward will talk about truck operations in Alaska in general and spend some time discussing hazardous materials transport issues. There will be power point presentation as well as ample opportunity for a question and answer period. Aves is the brand new Executive Director of the Alaska Trucking Association.



## HAMFEST 2006

This year, 2006, marks the 35th Anniversary of the Anchorage Amateur Radio Club Amateur Radio Flea Market better known as HAMFEST. The Flea Market started in 1971. HAMFEST provides amateur operators the opportunity to sell and exchange old equipment that they are no longer using or look for pieces and parts to repair vintage radios.

Over the years, the Anchorage HAMFEST has been at locations through out the city of Anchorage. The activities and speakers have varied over time. This year hopes to be one of the best. The HAMFEST 2006 will take place **at the Anchorage Senior Center**. Table will be available for sellers at \$10/each starting at 0900 and doors opening to the general public at 1000 AM. The HAMFEST will be two days long both Saturday and Sunday from 10AM to 4 PM. Food services will be provided by the senior center. The Anchorage Senior Center is located at: 1300 E 19<sup>th</sup> Avenue in Anchorage.

The HAMFEST will have speakers and seminars, VE Testing, **a raffle** including two radios (a **hand held on Saturday and a mobile/base radio on**

**Sunday**) and many other great prizes. You must be present to win and tickets cannot be transferred.

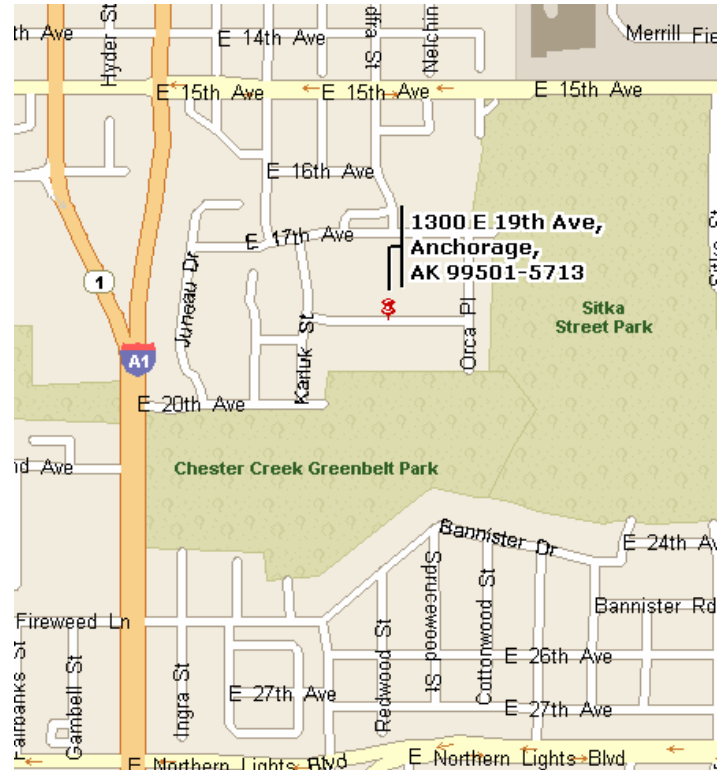

This year we are bringing back an old tradition, the **BANQUET Dinner**. Our Banquet dinner this year will be at the Sourdough Mining Company starting at 7PM on Saturday. We have invited several members of our club as Guests of Honor. We will be presenting several awards honoring many amateur radio operators that chartered and founded the Anchorage Amateur Radio Club as well as many of those who have contributed thousands of hours of volunteer service to the success of our organization. We also plan to bring back several of the historic awards from previous Banquets.

We will also be offering a **GRAND PRIZE** at the banquet dinner. This will be a complete portable packet station including Radio, laptop computer and pelican case. Tickets for the grand prize are limited to one ticket per paid club member in attendance at the Banquet Dinner. This provides an equal

opportunity for all club members in attendance to win the *GRAND PRIZE*.

**The cost for the banquet is a reasonable \$10/person.** A buffet dinner has been chosen. With current seating limited to 85 people, if you wish to attend, please respond to and contact Kathleen O'Keefe at 907-243-4675 or [kok@woodscross.org](mailto:kok@woodscross.org) to confirm your attendance so we can be sure to have room for all those who wish to attend. Transportation can be arranged and coordinated for those needing assistance to attend. Please contact Kathy for assistance.



## Thoughts on Emergency HF Communications

Larry Plessinger, AL7LW  
(Edited)

Greetings, fellow amateurs:

Since we have property and many friends in the Mat-Su Valley, we monitored much of the radio communications during the August 2006 Mat-Su flood emergency.

We wish to thank all the amateurs that volunteered and participated during this emergency for a job well done. Everyone we heard did an excellent job. We were particularly impressed with the efforts by everyone to assure that information transmitted was accurately received. Obviously everyone involved realized that misinformation can be more damaging than no information.

During this emergency, just as in nearly every disaster, the phone systems failed, both landline and cellular, and the complex, illogically structured government communications systems were inadequate, so once again the amateur community carried the ball.

**Now here's a little food-for-thought:** A few times during this emergency we heard discussions as to what HF emergency frequency should be guarded, and a few times 3.933 MHz was suggested. Although the Motley Group frequency is a common contact frequency for Alaskans, **traditionally the emergency HF (75-meter) guard frequency for Alaska is 3.920 MHz.** If we fail to maintain and

promote that tradition, those of us who monitor HF for that possible emergency cry from the wilderness will be forced to increase our monitoring spectrum and therefore decrease our effectiveness as monitors. Keep in mind that some of us already monitor three amateur frequencies, 3.920, 7.093 and 14.292, two marine frequencies, 2182 and 4125, and the state emergency frequency, 5167.5. Adding 3.933 to that mix would not be beneficial. The greater the number of stations that guard 3.920, and the greater the number of people who know that frequency is guarded, the greater the chance that someone with a damaged airplane or boat, or other emergency, far beyond VHF range, will be heard. Granted, the number of planes or boats with HF equipment is limited, but we have monitored or responded to six HF calls for help in the last 30 years: one from a wrecked plane, one from a dogsled, one from a remote cabin, one from a vehicle accident on the ALCAN, and two from sailboats in the Bering Sea and the North Pacific.

Emergencies can happen anytime, anywhere, not just during a flood or earthquake; be prepared.

Again, thank you all for your outstanding service.

Larry & Brenda, AL7LW - AL7LX



**Alaska QRP Club** meets the Third Friday of every month – 7:00 PM (Some show for dinner at 6PM): Hams with QRP (low power under 5 watts) and Homebrewing interests meet for a social meeting monthly. Meet at Dennys (in the back room) on DeBarr near Bragaw. Contact is Jim Larsen, AL7FS, [Jim@AL7FS.us](mailto:Jim@AL7FS.us) or 345-3190.

## A SPORTING MULTI-BAND PORTABLE VERTICAL

by John Reisenauer, Jr. KL7JR/K7ICE

When I came across a closeout deal on golf ball retrievers, you know the telescopic metal variety with a small cage on one end for retrieving golf balls out of water traps, I immediately knew what

my next antenna project would be. At \$6 each and 15 feet long when fully extended, the aluminum beauty tapered down into four sections from .75 inch to about .25 inch in diameter making it ideal for multi-band portable use. I remembered a previous article in QST where a vertical was made from a telescoping paint pole. I never could find one on sale so opted for this lighter version “look-a-like” that was easier on my wallet. While I was at it, I designed a drive on base support made from scrap lumber and PVC pipe to go along with my new vertical (large rocks or other heavy items will also work in-lieu-of a vehicle). Besides a few wood screws and hose clamps, I had less than \$10 invested in the antenna. I’ve experimented with verticals made from copper pipe or EMT over the years, so I knew this set up would also be an excellent performer on 10 through 20 meters.

Erecting the antenna was pretty simple and only took about 15 minutes. After all four sections were extended, I jumpered across each section’s plastic collar with a short piece of #12 stranded wire and two hose clamps and added an 18 inch long whip made of .25 aluminum tubing (a metal coat hanger or stiff wire cut to length also works!) to make the antenna 16 ft-4 inches, or .25 wl on 20 meters (234 divided by frequency in MHz). Next I slid the antenna down into the base and connected the coax and ground radials (note the ground ring made from plumbers tape). Alligator clamps work fine to terminate the radials to the 12 inch diameter ground ring. I like to use battery post clamps on the coax (center conductor of coax to pipe and braid to ground ring). I usually have good success with just 4-6 radials but you may want to put out as many as you can (I use 16 ft. long each as a minimum). I always toss one radial in the water if I’m near a river, lake or the sea to enlarge the ground plane and reduce QRM. I used my 15 foot long vertical with the 20m whip also on 17 and 15 meters with good results. You can easily retract the antenna to the proper length for use on 10 and 12 meters (about 8 ft-3 inches and 9 ft-4 inches respectively).

Casual operating during a May 2006 weekend of poor to fair band conditions, I worked 32 states plus Mexico and Italy on 20 meters, 19 states on 17 meters and West Africa and 7 states on 15 meters. Even though 10 and 12 meters were dead, I feel like I hit a hole-in-one with this aerial!



Complete antenna set up

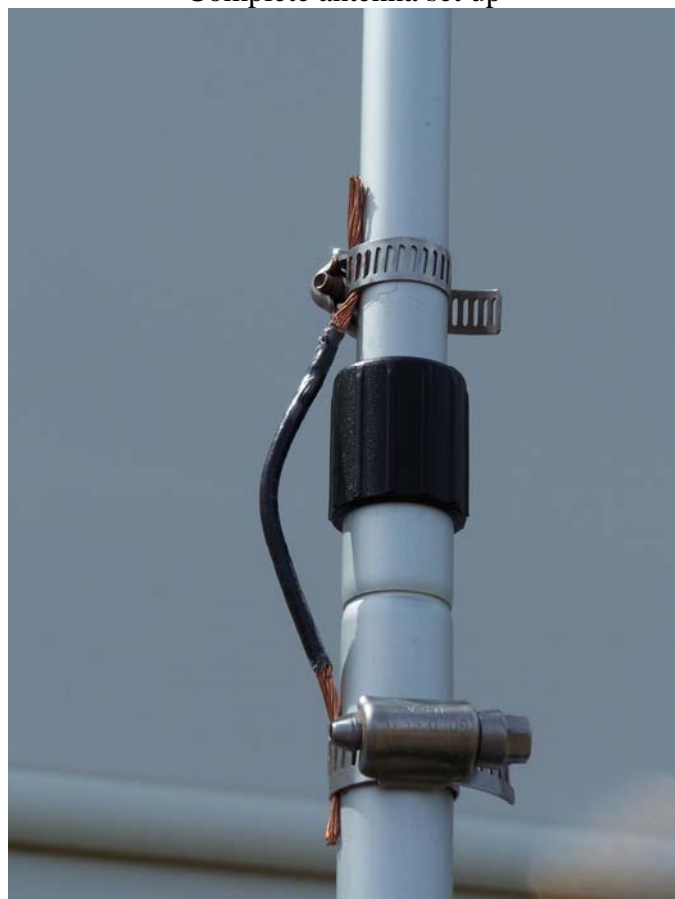

Jumper on telescopic section.



Quickie homebrew base from scrap lumber with ground ring and coax connections.



## ALASKA QSL Forwarding Service

Due to the cost of envelopes and labels, I'll have to raise the cost of mailing the QSL cards to \$0.12 per card on the first of May (individual's money already deposited will still be used at the \$0.10 rate until depleted). This will also allow me to cut the quantity of cards in an envelope to seven instead of ten, thus cutting down storage time.

In the past month I have forwarded close to 250 QSL cards directly to the countries of Japan, Germany, Russia, United Kingdom, Canada and Serbia.

Taking the cue from the AARL Outgoing QSL Service, please sort your cards as follows: Alphabetically by parent call sign prefix (AP, C6, CE, DL, ES, EZ, F, G, JA (JB, JC, JD), LY, PY, UN, YL, 5N, 9Y and so on). Canadian and Australian cards should be sorted by numerical callsign (VE1, VE2, VE3 & VK1, VK2, VK3 etc). NOTE: Some countries have a parent prefix and use additional prefixes, i.e. G (parent prefix) = M, 2E, 2I, 2M, 2W. Since my file is in Numerical/Alpha order, you can put the numbered prefix first, and please sort the cards as stated above though.

By combining all our individual country QSL cards I can make up a small package to send to the QSL Bureaus thus creating a savings and cutting down the delay time in receiving a return card. Remember the more people that use this QSL forwarding service, the cheaper it will become.

-- Jim KL7CDG

## Call for AARC Historical Documents

**Heather Hasper, KL7SP, has taken on the activity of collecting and organizing our Club historical documents. She is looking for AARC documents that you no longer want to maintain in your house. These might include newsletters, membership rosters, flyers, photos, or any other item of historical interest.**

Please contact Heather at [KL7SP@ARL.NET](mailto:KL7SP@ARL.NET) or via pager at 907-275-7474

## THREE TYPES OF HAMS?

### One Ham's Wonderings

=====

I've been wondering, after about five years as a Ham, I've seen, heard, and met quite a few different Hams and attitudes on pretty much all the different modes and bands, and both on and off the air. I've come to a conclusion of sorts; that there are three very different types of Hams...

**1: The "disgruntled" Ham.** This type of Ham is easy to find. They are very bitter, for reasons generally unknown or at least not understood by me, and they really do nothing to help out their fellow Amateurs. What they do is complain and whine a lot, get angry, yell, scream, post flames to

the discussion boards on the Internet and to various e-mail reflectors, cuss at their fellow Amateurs on the air, and are a general pain in the rear. They do not care about Amateur Radio, just themselves their selfishness, and complaining all the time about anything and everything. Kind of depressing when you think about them for too long.

**2: The Ham who wants help, and or is "new" to Amateur Radio.** Now this Ham could end up like either the first type of Ham, the third type of Ham, or just get out of Amateur Radio out of disgust. (Then we ALL lose.) This type of Ham just needs a helping hand, someone who is willing to help them set up their station, or maybe even upgrade! They tend to find only the "disgruntled" Hams, and end up leaving the Amateur Radio Service. Funny how most Amateurs never even notice this type of Ham, as they slowly fade away.

**3: The very rare Ham, the Ham who wants to help out, and does, in every way that he or she can.** This can be in the form of joining ARES, becoming a V.E., starting up Ham Radio classes (Hey, a first day Technician is perfectly qualified to teach!) Setting up a Club station, helping out the Community, or helping the second type of Ham. Keep in mind that this third type of Ham is very rare, and if you find one, don't lose touch. To bad, that this type of Ham seems to be a dying breed. They might not be, if a few more "type two" Hams were helped out by say the "type one Hams", if they (we), could get their (our), act together... Yes, "type three" Hams care about their fellow Hams, Amateur Radio, and it's future. They are not a part of the problem, as the "type one" hams are, but rather, are a part of the solution.

So, which "type" of Ham are you? Personally I try my best to be a "type three" Ham...

Food for thought!

"The time has come for all of us set aside our differences, help out all new Amateurs that are coming into our ranks, and help them to become the type of Amateur that we aspire to be." -- Clinton Herbert, AB7RG

Heather Hasper, KL7SP

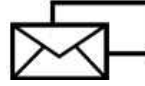

## KL7AA Mail Reflector

If you like to **stay in touch on KL7AA news** and other posts of local interest.

Step #1: First point your browser to (click the link below):  
<http://mailman.qth.net/mailman/listinfo/kl7aa>

Step #2: On the web page you will see a section titled "Subscribing to KL7AA". Enter your e-mail address in the "Your email address" entry box.

Step #3: Pick a password for your account and enter it in the box marked "Pick a password" and then enter the same password in the box marked "Reenter password to confirm". This password will be used to change your settings on the list such as digest mode, etc.

Step #4: If you would like the e-mails in daily digest form click yes on the line marked "Would you like to receive list mail batched in a daily digest?"

Step #5: Click on the "Subscribe" button below the information that you just entered.



### ALASKA STATE FAIR VOLUNTEERS

We need a few more volunteers to staff our informational booth at the Alaska State Fair. Fair **Dates are August 24<sup>th</sup> through September 4<sup>th</sup>.** The booth must be staffed on weekdays from 12-10PM and 10AM to 10PM on Weekends and Labor Day.

If you volunteer for the full day we will provide you with an admission ticket and a parking pass for your vehicle. **You can work shorter shifts but** if you do then you will need to cover your own entry and parking.

Additional details and to volunteer, email Judi Ramage at [amage@gci.net](mailto:amage@gci.net) or call 688-0290 or John Lynn at [JohnLynn@gci.net](mailto:JohnLynn@gci.net) or call 337-1091

We had loads of fun last year and met lots of wonderful folks. Come join us at the Fair.

## Students Chat With Space Traveler

KENAI: A station in orbit linked with Alaska kids for the first time.

adn.com story/photo



Flight director **Dale Hershberger (KL7XJ)**, left, helps IDEA student Rachel Mackie pose a question to NASA astronaut Jeff Williams aboard the International Space Station on Saturday at the Challenger Learning Center of Alaska in Kenai. The exercise was the first contact by Alaska students to someone on the space station. (Photo courtesy Challenger Learning Center of Alaska)

By ROSE COX  
Anchorage Daily News  
(Published: August 10, 2006)

Stars appear brighter when viewed from 200 miles above Earth. But they do not twinkle; that's a distortion caused by atmosphere, which is absent in space. And it's interesting to work in the International Space Station's weightless environment, where any surface can become the floor.

A group of third-through-eighth-graders got answers to some of their questions from an astronaut on the space station during an amateur radio transmission Saturday.

It was the first time Alaska students had a chance to talk to a crew member at the station. The 404,000-pound mass of technology orbiting Earth was developed by 16 countries collaborating to maintain a long-term presence in outer space.

NASA astronaut Jeff Williams, one of three astronauts visiting the space station during its 13th Expedition, fielded questions students posed from the Challenger Learning Center of Alaska in Kenai during a seven-minute window while the station was crossing over the Aleutian Islands.

It turns out there's not a whole lot of time for playing games on the space station, unless you count flying food and water droplets floating in midair.

"It was really cool to be able to talk to someone out in space and think about the differences here and there," said Rachel Mackie, 11.

The 15 students, enrolled in the IDEA (Interior Distance Education of Alaska) home-school program, linked up with the challenger center for a series of workshops focused on space science.

The rocketry workshop was Mackie's favorite.

"We made rockets out of paper and cardboard and launched them ... different fins make (the rockets) move differently."

The summer-long series of workshops has also covered space physiology (the effects of space on the human body) and robotics. It will culminate in a student mission at the challenger center Sept. 24, the date set for Williams' return to Earth. The mission will simulate what it would be like to be at mission control and in the space station.

"It's been cool to do the experiments and learn a little bit more about space each day," Mackie said. "It's actually really fun, so I don't think of it like school, but it is school."

Amateur radio operators, often called "ham" radio operators or simply "hams," use radio transmitters and receivers to communicate with each other. There are two ham radios onboard the space station and most astronauts visiting outer space for six-month stints are licensed to operate them.

Schools can sign up to talk to astronauts at the space station through the organization Amateur Radio on the International Space Station program, a

collaboration between Canada, Russia, European partners and Japan. But ARISS has about a yearlong waiting list.

So IDEA students did it the old-fashioned way -- they knew somebody who knew somebody.

Soldotna resident Gail Caldwell's husband, Joel Caldwell, went to high school with Williams in Wisconsin. The couple have followed his career and were in contact with him during his first space shuttle mission, Expedition 12, in 2000.

"When we got a letter at the beginning of the year saying he'd been accepted for the (13th Expedition) mission, we wanted to watch the launch," Gail Caldwell said.

They were able to view William's takeoff on the Russian Soyuz TMA 8 from Baikonur, Kazakhstan, on the big screen at the challenger center.

The Caldwell's home-school their three children -- Jacob, 12, Caleb, 10, and Tacy, 8 -- so it wasn't a far stretch to propose a series of workshops centered on Expedition 13. They pitched the plan to the IDEA program, which snapped it up.

"IDEA students have done other workshops with the center," said Debbie Mackie, Rachel's mom and an IDEA field representative. "But this was really unique."

The students watched Williams suit up for the launch, saw the Russian space ship dock at the station and have followed his activities via NASA satellite television.

Dale Hershberger (KL7XJ), a flight director for the Challenger Center, has been contacting astronauts at the space station for more than a year and tracks a lot of other satellites. He mounted a directional antenna to track the space station on the roof of the Challenger Center and wired it to a computer.

When the computer software indicated the space station was in range, the students lined up to quickly ask their questions.

"The challenger center is all about getting young minds directed toward science," Hershberger said.

Daily News reporter Rose Cox can be reached at [rcox@adn.com](mailto:rcox@adn.com).

FOR INFORMATION about the International Space Station and photos of Williams' six-hour spacewalk on Aug. 3, visit NASA at [www.nasa.gov/mission\\_pages/station/main/index.html](http://www.nasa.gov/mission_pages/station/main/index.html).

FOR MORE about amateur radio on the International Space Station, visit [www.arrl.org/ARISS/arissfaq.html](http://www.arrl.org/ARISS/arissfaq.html)



### **ARES Contact Information**

Heather Hasper, KL7SP  
[KL7SP@AARL.NET](mailto:KL7SP@AARL.NET)  
Pager: 907-275-7474

### **News from the Section Emergency Coordinator [ad4bl@arrl.net](mailto:ad4bl@arrl.net)**

I hope that all of you have had a great summer, it has been a challenging one in a lot of ways.

The Winlink system is up and operating in Fairbanks and Delta Junction. We will use it for the Mass Inoculation Exercise Oct 13. With this system we can send email messages between operating stations, around the state and outside. A number of stations off the grid are already using it for their personal email. We can also do attachments so we will be able to send data files for the agencies that we assist.

The SET will also be run in conjunction with the Mass Inoculation Exercise. The ACWN will also take NTS traffic during the event. If you would like to participate please let me know. [ad4bl@arrl.net](mailto:ad4bl@arrl.net).

If you are interested in emergency communications, please contact your local club or send me an email. There are training requirements necessitated by the changes since 9/11. If you want to help, it is important that you get the training.

Linda Mullen AD4BL SEC Alaska

## SEPTEMBER IS NATIONAL PREPAREDNESS MONTH

National Preparedness Month is a nationwide effort held each September to encourage Americans to take simple steps to prepare for emergencies in their homes, businesses and schools. This year, ARRL is once again a coalition member. National Preparedness Month 2006 is sponsored by the U.S. Department of Homeland Security (DHS). The agency will work with a wide variety of organizations, including local, state and federal government agencies and the private sector, to highlight the importance of family emergency preparedness and promote individual involvement through events and activities across the nation. More information is available at <http://www.ready.gov>.

The August issue of ARRL's "CONTACT!" features a wealth of information on September's National Preparedness Month and how to promote ARES in local media outlets. See <http://www.arrl.org/pio/contact/#current> and click on the August 2006 issue.



### One Man's QRP Spartan Sprint

AKA: The joys of QRP at the bottom of the sunspot cycle

The band seemed dead. S-meter read absolute zero. The band sounded like absolute zero. Then...out of the hiss came K7TQ in ID. Not loud but good copy. We worked. He knew my name! I had a contact. I was not skunked.

Then a second signal. I could not believe my luck. Two possible contacts in one contest. I calmed down, steadied my fist and called WB6HGJ in California. He was stronger than Randy. I was perspiring but I got him! My excitement mounted....

But then, the next 30 minutes I did not hear even one other signal in the hissssssss. I felt abandoned, rejected, set aside.

Then, like a ghost, came W4QO from Georgia. Up and down but mostly I could copy him. From 0145

to 0152 he tantalized me. CQ, CQ SP de W4QO SP over and over. I called and called but I knew in my heart it was hopeless. And then he was gone.

Everyone was gone. I was alone.

And there you have it...another great Spartan Sprint from the great state of Alaska. Remember what the Alaska Women say, "Alaska Men, where the odds are good but the goods are odd."

Til next time this is AL7FS...73.

Jim Larsen  
Die-hard QRPer who often dies hard.  
Anchorage, Alaska  
<http://www.AL7FS.us/>

Spartan Sprint information can be found at  
<http://www.arsgrp.com/>

This is the website of the Adventure Radio Society, a great group of men and women who combine amateur radio with their love of the outdoors. Their online newsletter can be accessed via the website.



### What is APRS; Automatic Packet Reporting System?

From: <http://eng.usna.navy.mil/~bruninga/aprs.html>

Submitted by Tom Rutigliano - NL7TZ

**OVERVIEW:** The Automatic Packet Reporting System was designed to support rapid, reliable exchange of information for local, tactical real-time events or nets. The concept is that each station with new information transmits his new data to everyone in the net and every station captures that information for consistent and standard display to all participants. Since the primary objective is consistent exchange of information between everyone, APRS established standard formats not only for the transmission of POSITION, STATUS, MESSAGES, and QUERIES, it also establishes guidelines for display so that users of different systems will still see the same consistent information displayed in a consistent manner (independent of the particular mapping system in use). [See APRS.TXT](#).

<http://eng.usna.navy.mil/~bruninga/APRS-docs/APRS.TXT>

## THE GOAL IS COMMUNICATIONS, -NOT- JUST VEHICLE TRACKING!

Notice that APRS is not a vehicle tracking system, thought that was added in the 1992 time frame when GPS began to be affordable for the common user. APRS is much more. APRS is to provide situational awareness to all operators of everything that is going on in his local area, whether it be Weather reporting, Direction Finding, objects pointing to ECHOLink and IRLP or Winlink nodes in an area, Traffic reporting and emergency response. All of this while providing instantaneous operator-to-operator keyboard messaging capability. There is even an APRS interface to the WinLINK system called **APRSlink** so that mobiles can send and receive Email without needing a PC.

<http://www.winlink.org/aprslink.htm>

Think of APRS as a signaling channel to reveal ALL amateur radio resources that are in range of the operator at any instant in time.

**UBIQUITOUS OPERATIONS:** Consistent with providing information on all resources within range, APRS must also work across all boundaries and in all areas of the continent for all travelers. For this reason, 144.39 MHz is dedicated to APRS throughout North America. Other continents have similar single frequencies such as 144.80 in Europe and 145.175 In Australia. Also after 14 years of evolution, APRS was greatly simplified beginning in the 2004 time frame to eliminate obsolete and inefficient routing. See the [New-N Paradigm](#).

<http://eng.usna.navy.mil/~bruninga/aprs/fix14439.html>

Now, there is only one recommended PATH everywhere, and it is VIA WIDEN-N for fixed stations where N is usually 2 in most metropolitan areas and no more than 3 most everywhere else. Mobiles can use VIA WIDE1-1, WIDE2-1 in those 2 hop areas to gain help from nearby WIDE1-1 fill-in digipeater. See the high density areas in the map below:

**APRS GLOBAL INTERNET SYSTEM:** Although APRS is a local, tactical real-time two-way communications system, the enormous free bandwidth of the Internet was added in the mid 1990's to allow global monitoring of all real-time data from all local communities around the world. Everything on any APRS frequency is being monitored locally and fed globally into the APRS internet system by hundreds of Igates, NL7TZ-2 is

the Igate in this area located at my QTH ([see live ones](#)).

<http://personal.riverusers.com/~aprswest/javAPRS/Igates.html>

Not only does this allow for global monitoring of any local activity, it also allows two-way point-to-point messaging between any two APRS users anywhere on the planet (that has an APRS infrastructure). Think of it as everything *goes in* so it is available to everyone, but the only thing that comes from the internet back to local RF are messages and selected position data requested locally.



## THE AMATEUR'S CODE

By: Paul M. Segal W9EEA (1928)

The Radio Amateur is:

### CONSIDERATE...

never knowingly operates in such a way as to lessen the pleasure of others.

### LOYAL...

offers loyalty, encouragement and support to other amateurs, local clubs and the American Radio Relay League, through which Amateur Radio in the United States is represented nationally and internationally.

### PROGRESSIVE...

With knowledge abreast of science, a well-built and efficient station and operation above reproach.

### FRIENDLY...

Slow and patient operating when requested; friendly advice and counsel to the beginner; kindly assistance, cooperation and consideration for the interests of others. These are the hallmarks of the amateur spirit.

### BALANCED...

Radio is an avocation, never interfering with duties owed to family, job, school, or community.

### PATRIOTIC...

Station and skill always ready for service to country and community.



## Feedback on last month's antenna stacking article.

From: Fusaro, Norm W3IZ <w3iz@arrl.org>  
To: Jim Larsen - AL7FS <jimlarsen2002@alaska.net>

Hi Jim.

I finished reading the newsletter (AARC) and the associated article on antenna stacking by Lew McCoy. Lew did this experiment long before there were antenna modeling programs and other tools that we use today. I believe you would do your readers a service by directing them to the 2006 ARRL Antenna Book and particularly page 11-27 where it talks about interaction between stacked Yagi antennas on different bands.

The fact is that there is interaction between antennas of different bands stacked on the same mast. Interlacing elements is also a difficult and almost impossible task. We could burn much midnight oil discussing antennas and stacking arrangements but it is best for the ham to do some research before attempting such arrangements.

73,  
Norm, W3IZ

*Norm is in charge of ARRL Affiliated Clubs and works at ARRL Headquarter. al7fs*



## AL7FS to step down as Newsletter Editor

After four years and 48 newsletters, I am handing off the editorship of the newsletter to Kathy O'Keefe, KL7KO, Mike O'Keefe, KL7MD and Heather Hasper, KL7SP.

I have had a lot of fun doing the newsletter each month and I have enjoyed sharing with you some of my own excitement as a ham radio operator. My ham career started at age 16 in March 1965 and in the following 41 years I have found that I still enjoy my hobby. This hobby has such a variety of technical topics that if one gets bored with one aspect, there is always another. I have tried HF, VHF, UHF, SSB, CW, RTTY, PSK-31, Packet, Moon Bounce, Satellites, fast scan TV, QRP, QRO, Homebrew, kits, Ragchewing, Contesting, and probably a bunch more that I can't think of as I type.

I encourage you to never give up on your hobby. If one thing fades in your interest, try something else. If you are near zero in your interest levels, put your rig on a shelf. Don't sell it. Your interest may come back after a break. I made the mistake of selling my radios during a dip in my interest one time and it took me several years to buy another radio and get back on the air. Renew your license...it costs nothing to do that.

Enough for now. Thank you for your support over the last four years. Without your articles and other input, the newsletter would have been a real chore. Mostly it was a pleasure. Many good technical articles were presented and you can still read all 48 past issues at <http://www.KL7AA.net>.

Take care,

Jim Larsen, AL7FS  
<http://www.AL7FS.us>



## Simple Rig CW on the Motley or Snipers Net

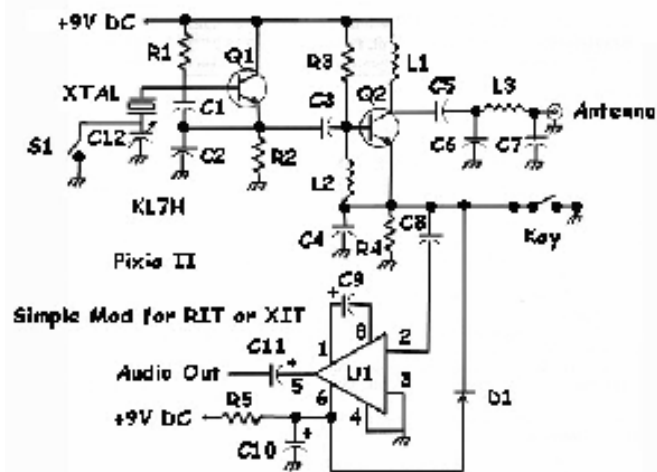

Read about this rig at  
<http://www.al7fs.us/AL7FS2.html>  
<http://www.qsl.net/kl7aqc/frpix.html>  
<http://www.qsl.net/we6w/text/pixie.html>



## Data You Can Use:

### Officers

**President** Jim Larsen, AL7FS president@kl7aa.net  
**Vice Pres.** Judi Ramage, WL7DX vicepresident@kl7aa.net  
**Secretary** Diane Olson, secretary@kl7aa.net  
**Treasurer** Heather Hasper, KL7SP treasurer@kl7aa.net  
**Trustee** Keith Clark, KL7MM trustee@kl7aa.net  
**Activities Chairman** Vacant

**News Letter Editor** Jim Larsen, AL7FS  
**Membership Chairman** Fred Erickson KL7FE  
membership@kl7aa.net  
**Past-Pres.** Jim Larsen, AL7FS pastpresident@kl7aa.net

### Three Year Board Members

Jim Wiley, KL7CC jwiley at alaska.net  
Paul Spatzek, WL7BF Paul.Spatzek at acsalaska.net  
Frank Pratt, KL7RX kl7rx at arrl.net

### One Year Board Members

Steve Jensen - KL0VZ, jensens at acsalaska.net  
Richard Kotsch - WL7CPX, richardkotsch at yahoo.com  
TJ Sheffield - KL7TS, kl7ts at hotmail.com  
Edward Moses - KL1KL, kl1kl at ak.net  
Mike O'Keefe - KL7MD, mok at gci.net  
Kathleen O'Keefe - KL7KO kok at woodscross.net  
Nick Casler - KL1XD ncasler at tertiary.net  
Art Morton - ALØU, Jam443 at Chugach.net  
Bill Reiter - KL7ITI, wwryter at cs.com

### AARC web page & Email contact addresses:

**Homepage:** <http://www.KL7AA.net/>  
**Webmaster:** webmaster@kl7aa.net  
**President:** president@kl7aa.net  
**Vice President:** vicepresident@kl7aa.net  
**Membership:** membership@kl7aa.net  
**Newsletter:** editor@kl7aa.net

### News Letter Submissions, Information or corrections:

Submissions must be received 2 weeks before meeting  
Email: editor@kl7aa.net  
Mail: 3445 Spinnaker Drive, Anchorage 99516

### Nets in Alaska:

The following nets are active in South-central Alaska:  
Alaska Sniper's Net 3.920 MHz 6:00 PM daily  
Alaska Bush Net 7.093 MHz 8:00 PM daily  
Alaska Motley Net 3.933 MHz 9:00 PM daily  
Alaska Pacific Net 14.292 MHz 8:00 AM M-F  
**ACWN (Alaska CW Net)** 3534, 7042 Daily @ 0700 –  
1000, and 1900 - 2400 Alaska Time - AL7N or KL5T  
monitoring.

Net Purpose: Formal NTS traffic via CW.  
No Name Net 146.85/.25 repeater Sundays 8:00 PM  
Grandson of SSB Net 144.20 USB Mondays 8:00 PM local  
Big City Simplex Net 146.520, 446.0, & 52.525 FM  
With Packet 145.01 Tuesdays 8:00 PM local  
ARES net 147.27/87 103.5Hz - Thursdays at 8:00 PM local  
PARKA net 147.30/90 Thursdays at 7:00 PM local  
ERC VHF Net 147.27/87 103.5Hz – Sunday 7:30 PM local  
ERC HF Net 3.880 MHz – Sunday 8:30PM local

**Any AARC sponsored repeater, with or without an auto-patch, will always be open to all licensed amateur radio operators in the area who are authorized to operate on those frequencies.**

### Anchorage & Mat Valley Area Repeaters-a/o Mar05

KL7AA systems at Flattop Mt., 2,200 ft  
146.94/34 MHz, 80 watts, autopatch, 141.3 Hz PL (problems)  
224.94/223.34, 25 watts, no patch, no PL  
444.70/449.70, 25 watts, autopatch, 141.3 PL  
**\*\*147.27/87 MHz, no patch, Mount Susitna 103.5 Hz**  
**\*\*443.3/448.3, no patch, Mount Susitna 103.5 Hz**  
KL7CC, Anchorage Hillside, SCRC & QCWA  
146.97/.37 MHz, 30 watts, autopatch, 103.5 Hz PL  
KL7M Anchorage Hillside  
147.21/.81 MHz, on IRLP, 97.4 Hz PL  
KL7ION at Mt. Gordon Lyon, PARKA 3,940 ft  
147.30/90, MHz - 80 watts, no patch, 141.3 Hz PL  
KL7AIR Elmendorf AFB, EARS  
146.67/.07, 107.2 Hz PL  
KL7JFU, KGB road, MARA club  
146.85/.25, autopatch, no PL  
Palmer IRLP  
146.64/.04, simplex patch, no PL  
Mile 58.3 Parks Highway IRLP  
147.09/.69 MHz, 97.4 Hz PL  
KL3K, Girdwood - IRLP  
146.76/16 MHz, 25 watts, no patch, 97.4 Hz PL  
South Anchorage IRLP  
146.79/19 MHz, 100 Hz PL  
Anchorage IRLP – KB8JXX  
146.82/22 tone unknown  
**South Central Area Simplex Frequencies**  
146.52 MHz Calling and Emergency frequency  
147.57 / 447.57 (crossband linked) HF spotters & chat, 103.5  
HZ PL  
146.49 MHz Anchorage area simplex chat  
146.43 MHz Mat Valley simplex chat  
147.42 MHz Peninsula simplex chat  
146.58 MHz Simplex IRLP - Wasilla Lake

## VE Testing in the Valley

Valley VE testing sessions will be held at the Wasilla Red Cross at 7 pm on the fourth Saturday of each month unless it is a major holiday weekend. Wasilla Red Cross is in the Westside Mall, next to Speedy Glass...it's just a click up from AIH hardware

### Internet Links, the favorites from our readers:

**QRP and Homebrew Links** <http://www.AL7FS.us>

**AARC** <http://www.KL7AA.net/>

**SCRC** <http://www.KL7G.org>

**EARS** <http://www.qsl.net/kl7air>

**MARA** <http://www.kl7jfu.com/>

**Moose Horn ARC** <http://www.alaksa.net/~kl7fg>

**ARES** <http://www.qsl.net/aresalaska>

**Practice Exams :** <http://www.AA9PW.com/>

**Fairbanks AARC:** <http://www.kl7kc.com/>

**Yukon Amateur Radio Association:**

<http://www.klondike.com/yara/index.html>

**Links for Homebrewers & QRPers**

<http://www.amqrp.org/misc/links.html>

**Solar Terrestrial Activity** <http://209.130.27.95/solar/>

**ARRL** <http://www.arrl.org/>

Propagation Report Recording 566-1819

*Please let us know if there are other clubs pages or good starting points that should appear here. Report dead links or bad info to [editor@kl7aa.net](mailto:editor@kl7aa.net).*

+==+==+==+==+==+==+

**NEWSLETTER ARTICLES:** All articles from members and interested persons are very welcome. If you wish to submit any articles, jokes, cartoons, please have it typed or neatly handwritten. It can be submitted by mail, computer disk or E-mail to the newsletter editor at the address listed above. Submissions must be in the hands of the editor **no later than the 10 days prior** to the meeting or it may not be included.

### Regular HAM Gatherings:

**Alaska QRP Club, Third Friday - 7:00 PM:** Hams with QRP (low power under 5 watts) and Homebrewing interests meet for a social meeting monthly. Meet at Denny's on DeBarr & Bragaw in the back room. Hungry QRPers start showing up about 6PM. Info contact Jim Larsen, AL7FS, [JimLarsen2002@alaska.net](mailto:JimLarsen2002@alaska.net) or 345-3190.

**Tuesday Lunch, 11:30 AM:** Dennys on Denali behind Sears. Several old timers show for this and have lots of stories to share.

**Thursdays Brunch, 9:30 AM:** Brunch NW corner of Debarr and Bragaw at Birch Tree Dining. A great bunch of folks attend this one.

**Saturdays Breakfast, 7:30 AM:** Here is a good way to get started on the weekend. Come and meet with some of the locals and have a great breakfast at American Diner, at the SE corner of Arctic and International. Great Fun.

## THIS MONTH'S EVENTS

**1<sup>st</sup> Friday each month - AARC general meeting - 7:00 PM** in the Carr-Gottstein Building, on the APU Campus. Talk in will be on 147.30+ repeater.

**1<sup>st</sup> Tuesday each month: VE License Exam 6:30 PM,** at the Hope Cottage offices, 540 W International. Bring photo ID, copy of license (if any) and any certificates of completion.

**1<sup>st</sup> Wednesday quarterly: EARS general meeting,** Meets quarterly at R1 North, next scheduled meeting is the first Wednesday of May at 1730. Additional meetings as required will be announced. Contact info - PO Box 7069, Elmendorf AFB 99506 or email Ron Keech, KL1PL for information. Email - [kl7air@qth.net](mailto:kl7air@qth.net) or [ronkeech@kl1pl.us](mailto:ronkeech@kl1pl.us) (home) 349-2442

**2<sup>nd</sup> Friday each month: SCRC general meeting at 7:00 PM** at Denny's on Denali Street. Talk in on 147.57 simplex.

**2<sup>nd</sup> Saturday each month: VE License Exams at 2:00 PM.** at Hope Cottage 540 W. International. Be sure to bring photo ID, copy of license (if any) and any certificates of completion.

**2<sup>nd</sup> Saturday each month: PARKA Meeting at 11:00 AM.** at Peggy's, across from Merrill Field.

**3<sup>rd</sup> Tuesday each month: AARC Board meeting at 7:00 PM** at Hope Cottage 540 W. International. All are invited and encouraged to attend.

**3<sup>rd</sup> Friday each month: Alaska QRP Club. 7:00PM** at Denny's on DeBarr in the back room. Info: Jim Larsen, 345-3190. Bring projects to share with the group. Some show up at 6:00PM to eat.

**3<sup>rd</sup> Saturday each month: ARES General meeting 9:30AM to 12:00 PM.** Call TJ Sheffield - KL7TS: kl7ts@arrl.net HM: 248-3864 for additional information. Also check for ARES Info at: <http://www.qsl.net/aresalaska/>

**The last Friday each month: MARA meeting at 7PM** Fire Station 61, located two blocks up Lucille Drive, from the Parks hwy. Talk-in help for the meeting can be acquired on either the 146.640 or 146.850 repeaters. Further details can be found by contacting Len Betts, KL7LB, [lclbak@yahoo.com](mailto:lclbak@yahoo.com).

## Who Do I Contact to Join AARC Or pay membership renewals?

**Fred Erickson KL7FE**

**12531 Alpine Dr**

**Anchorage, AK 99516-3121**

**frederickson (at) iname.com**

**Phone number: 345-2181**

Annual Dues are \$12 (prorated as appropriate)

Additional Member in same household is \$6.

Full Time Student is no charge.

Ask about Life Memberships.

Saturday, September 9<sup>th</sup> &  
Sunday September 10<sup>th</sup>, 2006

Anchorage Senior Center

10:00 AM - 4:00PM



# HAMFEST 2006



Doors open at 09:00 AM for Sellers and 10:00 AM for Buyers:

\$10.00 / Table for Sellers

## BANQUET DINNER

Sourdough Mining Company SAT. 7:00PM

Awards ceremony honoring our radio club heritage

and the Amateur Radio Operators that make our hobby great!

**Seminars**

**Raffle Prizes!**

# Anchorage Amateur

**Testing  
Sessions**

# Radio Club



# SCHEDULE

## Saturday

- 0900 Doors open for Vendors & Sellers
- 1000 Doors open for General Entry Buyers
- 1100 **TESTING SESSION**
- 1200 **LUNCH**
- 1300 SEMINARS:  
Antenna Modeling
- 1400 Propagation
- 1500 Repeaters: Location & Design
- 1900 **BANQUET DINNER:**  
Sourdough Mining Company

## Sunday

- 0900 Doors open for Vendors & Sellers
- 1000 Doors open for General Entry Buyers
- 1100 **TESTING SESSION**
- 1200 **LUNCH**
- 1300 SEMINARS:  
IRLP vs. Echolink
- 1400
- 1500
- 1600 Tear Down

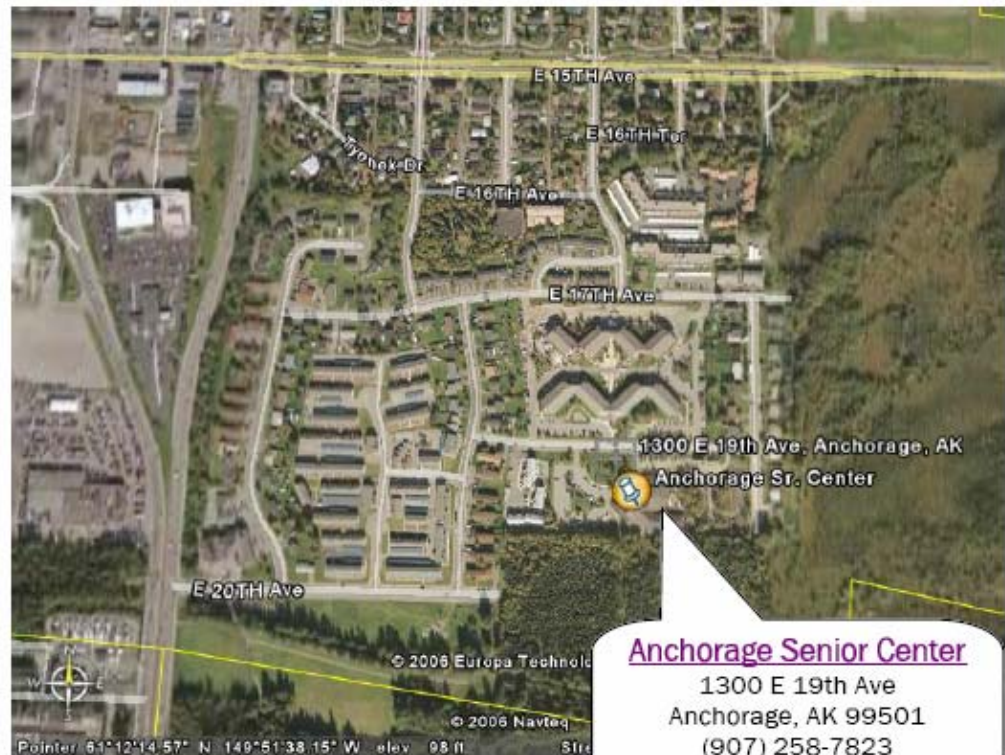

# TALES OF THE TRAIL



TIM COMFORT  
2006

**OUT OF THE DARK WOODS, THE MOUNTAIN IN SIGHT.  
ITS SNOWY SLOPES GLOW ORANGE AND PINK BRIGHT.  
A TRAIL'S END BEACON SAYING COME TO THE LIGHT.**

**IN MEMORY OF SUSAN BUTCHER**

**5 AUGUST 2006**

**THE HAM COMMUNITY OF ALASKA**